

Atomic structure of the carbon like ion Ca XV

N. Alwadie ^{1, 2} A. Almodlej ¹ N. Ben Nessib ^{1, 3}
and M. Dimitrijević ^{4, 5}

¹ Department of Physics and Astronomy, College of Sciences, King Saud University, Saudi Arabia

² Department of Physics, College of Sciences, King Khalid University, Saudi Arabia

³ GRPAA, INSAT, Centre Urbain Nord, University of Carthage, Tunis, Tunisia

⁴ Astronomical Observatory, Volgina 7, 11060 Belgrade 38, Serbia

⁵ Sorbonne Université, Observatoire de Paris, Université PSL, CNRS, LERMA, F-92190 Meudon, France

- **Introduction (Ca XV ion)**
- The Hartree-Fock Relativistic (HFR) theory

- **Introduction (Ca XV ion)**
- **The Hartree-Fock Relativistic (HFR) theory**
- **The Cowan atomic structure code 2018**

- **Introduction (Ca XV ion)**
- **The Hartree-Fock Relativistic (HFR) theory**
- **The Cowan atomic structure code 2018**
- **Atomic structure of the Ca XV ion**

- **Introduction (Ca XV ion)**
- **The Hartree-Fock Relativistic (HFR) theory**
- **The Cowan atomic structure code 2018**
- **Atomic structure of the Ca XV ion**
 - Energy levels

- **Introduction (Ca XV ion)**
- **The Hartree-Fock Relativistic (HFR) theory**
- **The Cowan atomic structure code 2018**
- **Atomic structure of the Ca XV ion**
 - Energy levels
 - Oscillator strengths and transition probabilities of the different transitions

- **Introduction (Ca XV ion)**
- **The Hartree-Fock Relativistic (HFR) theory**
- **The Cowan atomic structure code 2018**
- **Atomic structure of the Ca XV ion**
 - Energy levels
 - Oscillator strengths and transition probabilities of the different transitions
- **Conclusion**

- **Introduction (Ca XV ion)**
- **The Hartree-Fock Relativistic (HFR) theory**
- **The Cowan atomic structure code 2018**
- **Atomic structure of the Ca XV ion**
 - Energy levels
 - Oscillator strengths and transition probabilities of the different transitions
- **Conclusion**

- **Introduction (Ca XV ion)**
- **The Hartree-Fock Relativistic (HFR) theory**
- **The Cowan atomic structure code 2018**
- **Atomic structure of the Ca XV ion**
 - Energy levels
 - Oscillator strengths and transition probabilities of the different transitions
- **Conclusion**

Carbon-like ions

Carbon-like ions are highly abundant elements and their lines are prominent in both stellar and interstellar spectra and they are interesting for possible astrophysical plasma diagnostic applications.

They are also important for investigation in plasma physics, fusion research and plasma technologies.

Carbon-like ions

Carbon-like ions are highly abundant elements and their lines are prominent in both stellar and interstellar spectra and they are interesting for possible astrophysical plasma diagnostic applications.

They are also important for investigation in plasma physics, fusion research and plasma technologies.

Ca XV ion

Carbon-like ions

Carbon-like ions are highly abundant elements and their lines are prominent in both stellar and interstellar spectra and they are interesting for possible astrophysical plasma diagnostic applications.

They are also important for investigation in plasma physics, fusion research and plasma technologies.

Ca XV ion

One example of the carbon-like ions is " Ca XV ", which is a highly charged carbon-like ion that typically exists in high temperature plasma's and plays an important role for diagnostics and modeling.

We can obtain ionized calcium by many approaches, for example, Tokamaks or the solar flare plasma which contain Extreme Ultra-Violet (XUV) solar emission lines of highly ionized calcium.

Carbon-like ions

Carbon-like ions are highly abundant elements and their lines are prominent in both stellar and interstellar spectra and they are interesting for possible astrophysical plasma diagnostic applications.

They are also important for investigation in plasma physics, fusion research and plasma technologies.

Ca XV ion

One example of the carbon-like ions is " Ca XV ", which is a highly charged carbon-like ion that typically exists in high temperature plasma's and plays an important role for diagnostics and modeling.

We can obtain ionized calcium by many approaches, for example, Tokamaks or the solar flare plasma which contain Extreme Ultra-Violet (XUV) solar emission lines of highly ionized calcium.

Carbon-like ions

Carbon-like ions are highly abundant elements and their lines are prominent in both stellar and interstellar spectra and they are interesting for possible astrophysical plasma diagnostic applications.

They are also important for investigation in plasma physics, fusion research and plasma technologies.

Ca XV ion

One example of the carbon-like ions is " Ca XV ", which is a highly charged carbon-like ion that typically exists in high temperature plasma's and plays an important role for diagnostics and modeling.

We can obtain ionized calcium by many approaches, for example, Tokamaks or the solar flare plasma which contain Extreme Ultra-Violet (XUV) solar emission lines of highly ionized calcium.

In quantum physics the basic equation to be solved is the Schrödinger equation:

$$\left[\sum_{i=1}^N \left(-\frac{1}{2} \nabla_{r_i}^2 - \frac{Z}{r_i} \right) + \sum_{i < j=1}^N \frac{1}{r_{ij}} \right] \Psi(q_1, q_2, \dots, q_N) = E \Psi(q_1, q_2, \dots, q_N)$$

In quantum physics the basic equation to be solved is the Schrödinger equation:

$$\left[\sum_{i=1}^N \left(-\frac{1}{2} \nabla_{r_i}^2 - \frac{Z}{r_i} \right) + \sum_{i < j=1}^N \frac{1}{r_{ij}} \right] \Psi(q_1, q_2, \dots, q_N) = E \Psi(q_1, q_2, \dots, q_N)$$

But in the case of atoms consisting of two or more electrons, we cannot solve exactly this equation, so approximate methods must be used:

In quantum physics the basic equation to be solved is the Schrödinger equation:

$$\left[\sum_{i=1}^N \left(-\frac{1}{2} \nabla_{r_i}^2 - \frac{Z}{r_i} \right) + \sum_{i < j=1}^N \frac{1}{r_{ij}} \right] \Psi(q_1, q_2, \dots, q_N) = E \Psi(q_1, q_2, \dots, q_N)$$

But in the case of atoms consisting of two or more electrons, we cannot solve exactly this equation, so approximate methods must be used:

"Hartree-Fock Relativistic (HFR) Theory"

Obtaining wavefunctions for the radial equation to have atomic structure data (energy levels, oscillator strengths, ...)

In quantum physics the basic equation to be solved is the Schrödinger equation:

$$\left[\sum_{i=1}^N \left(-\frac{1}{2} \nabla_{r_i}^2 - \frac{Z}{r_i} \right) + \sum_{i < j=1}^N \frac{1}{r_{ij}} \right] \Psi(q_1, q_2, \dots, q_N) = E \Psi(q_1, q_2, \dots, q_N)$$

But in the case of atoms consisting of two or more electrons, we cannot solve exactly this equation, so approximate methods must be used:

"Hartree-Fock Relativistic (HFR) Theory"

Obtaining wavefunctions for the radial equation to have atomic structure data (energy levels, oscillator strengths, ...)

The N-electron wavefunction used is the Slater Determinant:

$$\Psi(q_1, q_2, \dots, q_N) = \frac{1}{\sqrt{N!}} \begin{vmatrix} u_\alpha(q_1) & u_\beta(q_1) & \cdots & u_\nu(q_1) \\ u_\alpha(q_2) & u_\beta(q_2) & \cdots & u_\nu(q_2) \\ \vdots & \cdots & \cdots & \vdots \\ u_\alpha(q_N) & u_\beta(q_N) & \cdots & u_\nu(q_N) \end{vmatrix}$$

The N-electron wavefunction used is the Slater Determinant:

$$\Psi(q_1, q_2, \dots, q_N) = \frac{1}{\sqrt{N!}} \begin{vmatrix} u_\alpha(q_1) & u_\beta(q_1) & \cdots & u_\nu(q_1) \\ u_\alpha(q_2) & u_\beta(q_2) & \cdots & u_\nu(q_2) \\ \vdots & \cdots & \cdots & \vdots \\ u_\alpha(q_N) & u_\beta(q_N) & \cdots & u_\nu(q_N) \end{vmatrix}$$

The Hartree-Fock Relativistic (HFR) theory

12th SCSSLA
3-7. June 2019
Vrdnik, Serbia

6

$$\left[-\frac{1}{2} \nabla_{r_i}^2 - \frac{Z}{r_i} \right] u_\lambda(q_i) + \left[\sum_{\mu} \int u_{\mu}^*(q_i) \frac{1}{r_{ij}} u_{\mu}(q_j) dq_j \right] u_\lambda(q_i) - \left[\sum_{\mu} \int u_{\mu}^*(q_j) \frac{1}{r_{ij}} u_\lambda(q_j) dq_j \right] u_\lambda(q_i) = E_\lambda u_\lambda(q_i); \lambda, \mu = \alpha, \beta, \dots, \nu$$

The solution of this equation is:

$$\left[-\frac{1}{2} \nabla_{r_i}^2 - \frac{Z}{r_i} \right] u_\lambda(q_i) + \left[\sum_{\mu} \int u_{\mu}^*(q_i) \frac{1}{r_{ij}} u_{\mu}(q_j) dq_j \right] u_\lambda(q_i) - \left[\sum_{\mu} \int u_{\mu}^*(q_j) \frac{1}{r_{ij}} u_\lambda(q_j) dq_j \right] u_\lambda(q_i) = E_\lambda u_\lambda(q_i); \lambda, \mu = \alpha, \beta, \dots, \nu$$

The solution of this equation is:

$$E_\lambda = I_\lambda + \sum_{\mu} [J_{\lambda\mu} - K_{\lambda\mu}]$$

$$\left[-\frac{1}{2}\nabla_{r_i}^2 - \frac{Z}{r_i} \right] u_\lambda(q_i) + \left[\sum_{\mu} \int u_{\mu}^*(q_i) \frac{1}{r_{ij}} u_{\mu}(q_j) dq_j \right] u_\lambda(q_i) - \left[\sum_{\mu} \int u_{\mu}^*(q_j) \frac{1}{r_{ij}} u_\lambda(q_j) dq_j \right] u_\lambda(q_i) = E_\lambda u_\lambda(q_i); \lambda, \mu = \alpha, \beta, \dots, \nu$$

The solution of this equation is:

$$E_\lambda = I_\lambda + \sum_{\mu} [J_{\lambda\mu} - K_{\lambda\mu}]$$

$$\text{Where, } I_\lambda = \langle u_\lambda(q_i) | \hat{h}_i | u_\lambda(q_i) \rangle ; \hat{h}_i = -\frac{1}{2}\nabla_{r_i}^2 - \frac{Z}{r_i}$$

$$J_{\lambda\mu} = \langle u_\lambda(q_i) u_\mu(q_j) | \frac{1}{r_{ij}} | u_\lambda(q_i) u_\mu(q_j) \rangle$$

$$K_{\lambda\mu} = \langle u_\lambda(q_i) u_\mu(q_j) | \frac{1}{r_{ij}} | u_\mu(q_i) u_\lambda(q_j) \rangle$$

$$\left[-\frac{1}{2}\nabla_{r_i}^2 - \frac{Z}{r_i} \right] u_\lambda(q_i) + \left[\sum_{\mu} \int u_{\mu}^*(q_i) \frac{1}{r_{ij}} u_{\mu}(q_j) dq_j \right] u_\lambda(q_i) - \left[\sum_{\mu} \int u_{\mu}^*(q_j) \frac{1}{r_{ij}} u_\lambda(q_j) dq_j \right] u_\lambda(q_i) = E_\lambda u_\lambda(q_i); \lambda, \mu = \alpha, \beta, \dots, \nu$$

The solution of this equation is:

$$E_\lambda = I_\lambda + \sum_{\mu} [J_{\lambda\mu} - K_{\lambda\mu}]$$

Where, $I_\lambda = \langle u_\lambda(q_i) | \hat{h}_i | u_\lambda(q_i) \rangle$; $\hat{h}_i = -\frac{1}{2}\nabla_{r_i}^2 - \frac{Z}{r_i}$

$$J_{\lambda\mu} = \langle u_\lambda(q_i) u_\mu(q_j) | \frac{1}{r_{ij}} | u_\lambda(q_i) u_\mu(q_j) \rangle$$

$$K_{\lambda\mu} = \langle u_\lambda(q_i) u_\mu(q_j) | \frac{1}{r_{ij}} | u_\mu(q_i) u_\lambda(q_j) \rangle$$

We used the first eight configurations of Ca XV:

$2s^2 2p^2$

$2s^2 2p 3p$

$2s^2 2p 4p$

$2s 2p^3$

$2s^2 2p 3s$

$2s^2 2p 4s$

$2s^2 2p 5s$

$2s^2 2p 3d$

We used the first eight configurations of Ca XV:

$2s^2 2p^2$

$2s^2 2p 3p$

$2s^2 2p 4p$

$2s 2p^3$

$2s^2 2p 3s$

$2s^2 2p 4s$

$2s^2 2p 5s$

$2s^2 2p 3d$

as input of the Cowan atomic structure code (2018).

-Kramida, A., A suite of atomic structure codes originally developed by R. D. Cowan adapted for Windows-based personal computers., NIST, <https://doi.org/10.18434/T4/1502500> [10 January, 2019]

We used the first eight configurations of Ca XV:

$2s^2 2p^2$

$2s^2 2p 3p$

$2s^2 2p 4p$

$2s 2p^3$

$2s^2 2p 3s$

$2s^2 2p 4s$

$2s^2 2p 5s$

$2s^2 2p 3d$

as input of the Cowan atomic structure code (2018).

-Kramida, A., A suite of atomic structure codes originally developed by R. D. Cowan adapted for Windows-based personal computers., NIST, <https://doi.org/10.18434/T4/1502500> [10 January, 2019]

The Cowan atomic structure code (2018)

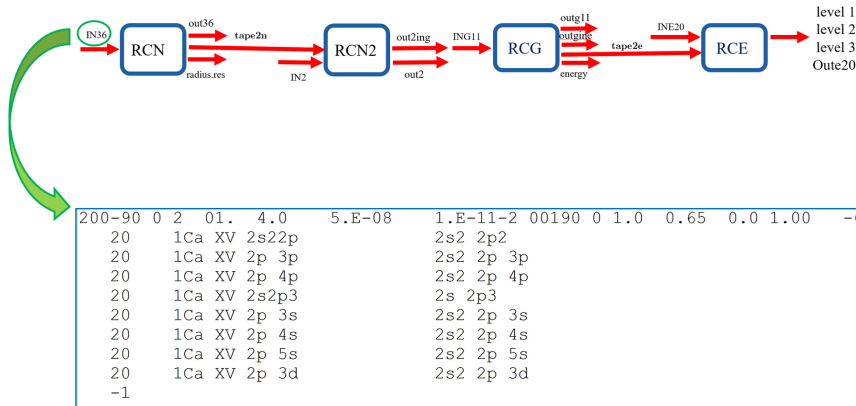

The Cowan atomic structure code (2018)

12th SC SLISA
3-7. June 2019
Vrdnik, Serbia

8

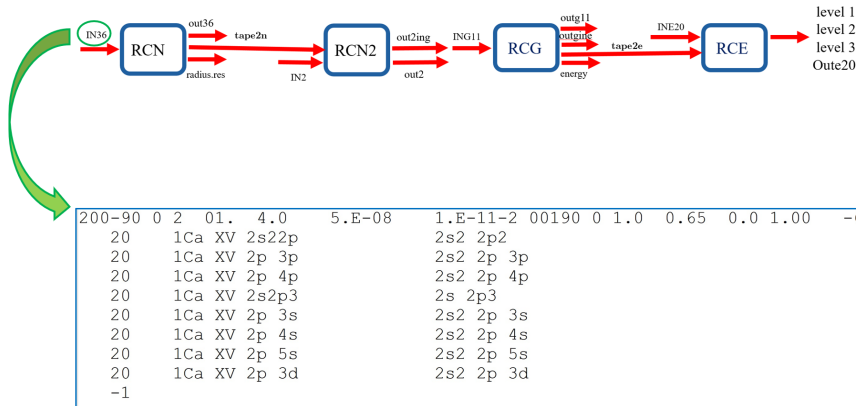

The Cowan atomic structure code (2018)

12th SCSLSA
3-7. June 2019
Vrdnik, Serbia

9

```
1 G5INP 0 10 0 0.00002      0011111 1 00000000 9499949494 5.00 1 07200 0.0  
2 -1
```



The Cowan atomic structure code (2018)

12th SCSSLA
3-7. June 2019
Vrdnik, Serbia

9

```
1 G5INP 0 10 0 0.00002 0011111 1 00000000 9499949494 5.00 1 07200 0.0  
2 -1
```

The Slater scalings for highly ionized

94% | 99% | 94% | 94% | 94%

F^K the radial integration between equivalent electrons

ξ_{nl} the Spin-orbit parameters

F^K the radial integration between nonequivalent electrons

G^K the exchange integral between nonequivalent electrons

R^K the radial configuration interaction integrals

The Cowan atomic structure code (2018)

12th SCSSLA
3-7. June 2019
Vrdnik, Serbia

9

```
1 G5INP 0 10 0 0.00002 0011111 1 00000000 9499949494 5.00 1 07200 0.0  
2 -1
```

The Slater scalings for highly ionized

94% | 99% | 94% | 94% | 94%

- F^K the radial integration between equivalent electrons
- ξ_{nl} the Spin-orbit parameters
- F^K the radial integration between nonequivalent electrons
- G^K the exchange integral between nonequivalent electrons
- R^K the radial configuration interaction integrals

All these ratios are normally used for reasonably good ab initio predictions when using Cowan's Code.

The Cowan atomic structure code (2018)

12th SCSSLA
3-7. June 2019
Vrdnik, Serbia

9

```
1 G5INP 0 10 0 0.00002 0011111 1 00000000 9499949494 5.00 1 07200 0.0  
2 -1
```

The Slater scalings for highly ionized

94% | 99% | 94% | 94% | 94%

- F^K the radial integration between equivalent electrons
- ξ_{nl} the Spin-orbit parameters
- F^K the radial integration between nonequivalent electrons
- G^K the exchange integral between nonequivalent electrons
- R^K the radial configuration interaction integrals

All these ratios are normally used for reasonably good ab initio predictions when using Cowan's Code.

Atomic structure of the Ca XV ion

1. Energy levels of the Ca XV:

"Energy levels for the configuration $2s^2 2p^2$ of Ca XV."

$E(\text{NIST})$ are from NIST database, $E(\text{CW})$ are the energy levels calculated by using the Cowan (CW) code, and $E(\text{EK})$ calculated by Ekman et al. using the MCDHF method. All energies are in cm^{-1} .

Atomic structure of the Ca XV ion

1. Energy levels of the Ca XV:

"Energy levels for the configuration $2s^2 2p^2$ of Ca XV."

E(NIST) are from NIST database, E(CW) are the energy levels calculated by using the Cowan (CW) code, and E(EK) calculated by Ekman et al. using the MCDHF method. All energies are in cm^{-1} .

Conf.	Term	J	E(NIST)	E(CW)	E(EK)
$2s^2 2p^2$	$3P$	0	0	0	0
$2s^2 2p^2$	$3P$	1	17559	16353	17553
$2s^2 2p^2$	$3P$	2	35923	35171	35920
$2s^2 2p^2$	$1D$	2	108600	104491	108736
$2s^2 2p^2$	$1S$	0	197670	214620	197839
				4.3%	0.1%

-Ekman et al. (2014), *Astronomy and Astrophysics*, **564**, A24.

-Kramida, A. et al. 2018, *NIST Atomic Spectra Database* (ver. 5.6.1). <https://physics.nist.gov/asd> [18 April,

2019]

Atomic structure of the Ca XV ion

1. Energy levels of the Ca XV:

"Energy levels for the configuration $2s^2 2p^2$ of Ca XV."

E(NIST) are from NIST database, E(CW) are the energy levels calculated by using the Cowan (CW) code, and E(EK) calculated by Ekman et al. using the MCDHF method. All energies are in cm^{-1} .

Conf.	Term	J	E(NIST)	E(CW)	E(EK)
$2s^2 2p^2$	3P	0	0	0	0
$2s^2 2p^2$	3P	1	17559	16353	17553
$2s^2 2p^2$	3P	2	35923	35171	35920
$2s^2 2p^2$	1D	2	108600	104491	108736
$2s^2 2p^2$	1S	0	197670	214620	197839
				4.3%	0.1%

-Ekman et al. (2014), *Astronomy and Astrophysics*, **564**, A24.

-Kramida, A. et al. 2018, *NIST Atomic Spectra Database* (ver. 5.6.1). <https://physics.nist.gov/asd> [18 April,

2019]

"Energy levels for the configuration $2s 2p^3$ of Ca XV."

E(NIST) are from NIST database, E(CW) are the energy levels calculated by using the Cowan (CW) code, and E(EK) calculated by Ekman et al. using the MCDHF method. All energies are in cm^{-1} .

"Energy levels for the configuration $2s 2p^3$ of Ca XV."

E(NIST) are from NIST database, E(CW) are the energy levels calculated by using the Cowan (CW) code, and E(EK) calculated by Ekman et al. using the MCDHF method. All energies are in cm^{-1} .

Conf.	Term	J	E(NIST)	E(CW)	E(EK)
$2s 2p^3$	$^5S^\circ$	2	275900	311928	275788
$2s 2p^3$	$^3D^\circ$	3	500230	533862	500273
$2s 2p^3$	$^3D^\circ$	2	496680	529034	496724
$2s 2p^3$	$^3D^\circ$	1	497570	529652	497632
$2s 2p^3$	$^3P^\circ$	1	582780	607890	582942
$2s 2p^3$	$^3P^\circ$	2	585670	611053	585800
$2s 2p^3$	$^3P^\circ$	0	581730	606177	581886
$2s 2p^3$	$^3D^\circ$	2	729650	759011	730043
$2s 2p^3$	$^3S^\circ$	1	728880	757132	729176
$2s 2p^3$	$^3P^\circ$	1	814380	835599	814815
				5.6%	0.02%

"Energy levels for the configuration $2s\ 2p^3$ of Ca XV."

E(NIST) are from NIST database, E(CW) are the energy levels calculated by using the Cowan (CW) code, and E(EK) calculated by Ekman et al. using the MCDHF method. All energies are in cm^{-1} .

Conf.	Term	J	E(NIST)	E(CW)	E(EK)
$2s\ 2p^3$	$^5S^\circ$	2	275900	311928	275788
$2s\ 2p^3$	$^3D^\circ$	3	500230	533862	500273
$2s\ 2p^3$	$^3D^\circ$	2	496680	529034	496724
$2s\ 2p^3$	$^3D^\circ$	1	497570	529652	497632
$2s\ 2p^3$	$^3P^\circ$	1	582780	607890	582942
$2s\ 2p^3$	$^3P^\circ$	2	585670	611053	585800
$2s\ 2p^3$	$^3P^\circ$	0	581730	606177	581886
$2s\ 2p^3$	$^3D^\circ$	2	729650	759011	730043
$2s\ 2p^3$	$^3S^\circ$	1	728880	757132	729176
$2s\ 2p^3$	$^3P^\circ$	1	814380	835599	814815

5.6% 0.02%

Atomic structure of the Ca XV ion

"Energy levels for configurations $2s^2 2p ns$ ($n = 3 - 5$) of Ca XV."

E(NIST) are from NIST database, E(CW) are the energy levels calculated by using the Cowan (CW) code, and E(EK) calculated by Ekman et al. using the MCDHF method. All energies are in cm^{-1} .

Conf.	Term	J	E(NIST)	E(CW)	E(EK)
$2s^2 2p3s$	$3p^o$	0	-	4392032	4079795
$2s^2 2p3s$	$3p^o$	1	-	4396297	4084845
$2s^2 2p3s$	$3p^o$	2	-	4428144	4115926
$2s^2 2p3s$	$1p^o$	1	-	4441352	4134012
$2s^2 2p4s$	$3p^o$	0	-	4395728	5520070
$2s^2 2p4s$	$3p^o$	1	-	4396731	5522133
$2s^2 2p4s$	$3p^o$	2	-	4431652	5556429
$2s^2 2p4s$	$1p^o$	1	-	4433840	5561725
$2s^2 2p5s$	$3p^o$	0	-	4657441	-
$2s^2 2p5s$	$3p^o$	1	-	4657861	-
$2s^2 2p5s$	$3p^o$	2	-	4693386	-
$2s^2 2p5s$	$1p^o$	1	-	4694256	-

"Energy levels for configurations $2s^2 2p ns$ ($n = 3 - 5$) of Ca XV."

E(NIST) are from NIST database, E(CW) are the energy levels calculated by using the Cowan (CW) code, and E(EK) calculated by Ekman et al. using the MCDHF method. All energies are in cm^{-1} .

Conf.	Term	J	E(NIST)	E(CW)	E(EK)
$2s^2 2p3s$	$3p^o$	0	-	4392032	4079795
$2s^2 2p3s$	$3p^o$	1	-	4396297	4084845
$2s^2 2p3s$	$3p^o$	2	-	4428144	4115926
$2s^2 2p3s$	$1p^o$	1	-	4441352	4134012
$2s^2 2p4s$	$3p^o$	0	-	4395728	5520070
$2s^2 2p4s$	$3p^o$	1	-	4396731	5522133
$2s^2 2p4s$	$3p^o$	2	-	4431652	5556429
$2s^2 2p4s$	$1p^o$	1	-	4433840	5561725
$2s^2 2p5s$	$3p^o$	0	-	4657441	-
$2s^2 2p5s$	$3p^o$	1	-	4657861	-
$2s^2 2p5s$	$3p^o$	2	-	4693386	-
$2s^2 2p5s$	$1p^o$	1	-	4694256	-

"Energy levels for the configuration $2s^2 2p 3p$ of Ca XV."

E(NIST) are from NIST database, E(CW) are the energy levels calculated by using the Cowan (CW) code, and E(EK) calculated by Ekman et al. using the MCDHF method. All energies are in cm^{-1} .

Conf.	Term	J	E(NIST)	E(CW)	E(EK)
$2s^2 2p3p$	3S	1	-	4476007	4257457
$2s^2 2p3p$	1P	1	-	4446957	4228086
$2s^2 2p3p$	3D	1	-	4424400	4205709
$2s^2 2p3p$	3D	2	-	4445944	4229376
$2s^2 2p3p$	3D	3	-	4472023	4255295
$2s^2 2p3p$	3P	0	-	4475994	4250224
$2s^2 2p3p$	3P	1	-	4494910	4270847
$2s^2 2p3p$	3P	2	-	4501838	4276163
$2s^2 2p3p$	1D	2	-	4528268	4314496
$2s^2 2p3p$	1S	0	-	4567681	4361378

"Energy levels for the configuration $2s^2 2p 3p$ of Ca XV."

E(NIST) are from NIST database, E(CW) are the energy levels calculated by using the Cowan (CW) code, and E(EK) calculated by Ekman et al. using the MCDHF method. All energies are in cm^{-1} .

Conf.	Term	J	E(NIST)	E(CW)	E(EK)
$2s^2 2p3p$	3S	1	-	4476007	4257457
$2s^2 2p3p$	1P	1	-	4446957	4228086
$2s^2 2p3p$	3D	1	-	4424400	4205709
$2s^2 2p3p$	3D	2	-	4445944	4229376
$2s^2 2p3p$	3D	3	-	4472023	4255295
$2s^2 2p3p$	3P	0	-	4475994	4250224
$2s^2 2p3p$	3P	1	-	4494910	4270847
$2s^2 2p3p$	3P	2	-	4501838	4276163
$2s^2 2p3p$	1D	2	-	4528268	4314496
$2s^2 2p3p$	1S	0	-	4567681	4361378

"Energy levels for the configuration $2s^2 2p 4p$ of Ca XV."

E(NIST) are from NIST database, E(CW) are the energy levels calculated by using the Cowan (CW) code, and E(EK) calculated by Ekman et al. using the MCDHF method. All energies are in cm^{-1} .

Conf.	Term	J	E(NIST)	E(CW)	E(EK)
$2s^2 2p4p$	3S	1	-	4491238	5618735
$2s^2 2p4p$	1P	1	-	4487896	5612050
$2s^2 2p4p$	3D	1	-	4450829	5572096
$2s^2 2p4p$	3D	2	-	4456178	5583680
$2s^2 2p4p$	3D	3	-	4488453	5613455
$2s^2 2p4p$	3P	0	-	4459660	5590557
$2s^2 2p4p$	3P	1	-	4455693	5582839
$2s^2 2p4p$	3P	2	-	4491171	5619232
$2s^2 2p4p$	1D	2	-	4496043	5631037
$2s^2 2p4p$	1S	0	-	4501924	-

"Energy levels for the configuration $2s^2 2p 4p$ of Ca XV."

E(NIST) are from NIST database, E(CW) are the energy levels calculated by using the Cowan (CW) code, and E(EK) calculated by Ekman et al. using the MCDHF method. All energies are in cm^{-1} .

Conf.	Term	J	E(NIST)	E(CW)	E(EK)
$2s^2 2p4p$	3S	1	-	4491238	5618735
$2s^2 2p4p$	1P	1	-	4487896	5612050
$2s^2 2p4p$	3D	1	-	4450829	5572096
$2s^2 2p4p$	3D	2	-	4456178	5583680
$2s^2 2p4p$	3D	3	-	4488453	5613455
$2s^2 2p4p$	3P	0	-	4459660	5590557
$2s^2 2p4p$	3P	1	-	4455693	5582839
$2s^2 2p4p$	3P	2	-	4491171	5619232
$2s^2 2p4p$	1D	2	-	4496043	5631037
$2s^2 2p4p$	1S	0	-	4501924	-

Atomic structure of the Ca XV ion

"Energy levels for the configuration $2s^2 2p 3d$ of Ca XV."

E(NIST) are from NIST database, E(CW) are the energy levels calculated by using the Cowan (CW) code, and E(EK) calculated by Ekman et al. using the MCDHF method. All energies are in cm^{-1} .

Conf.	Term	J	E(NIST)	E(CW)	E(EK)
$2s^2 2p3d$	$3F^\circ$	2	4363300	3951477	4363635
$2s^2 2p3d$	$3F^\circ$	3	4379400	3963833	4378814
$2s^2 2p3d$	$3F^\circ$	4	-	3988654	4401309
$2s^2 2p3d$	$1D^\circ$	2	-	3966033	4385007
$2s^2 2p3d$	$3D^\circ$	1	4399500	3975409	4402470
$2s^2 2p3d$	$3D^\circ$	2	4411500	3991878	4413002
$2s^2 2p3d$	$3D^\circ$	3	4426400	4000316	4425526
$2s^2 2p3d$	$3P^\circ$	2	4435400	4006954	4433389
$2s^2 2p3d$	$3P^\circ$	1	4434500	4008947	4435381
$2s^2 2p3d$	$3P^\circ$	0	-	4010358	4436968
$2s^2 2p3d$	$1F^\circ$	3	4475000	4032514	4474373
$2s^2 2p3d$	$1P^\circ$	1	4473400	4032524	4475119

9.6% 0.03%

Atomic structure of the Ca XV ion

"Energy levels for the configuration $2s^2 2p 3d$ of Ca XV."

E(NIST) are from NIST database, E(CW) are the energy levels calculated by using the Cowan (CW) code, and E(EK) calculated by Ekman et al. using the MCDHF method. All energies are in cm^{-1} .

Conf.	Term	J	E(NIST)	E(CW)	E(EK)
$2s^2 2p3d$	$3F^\circ$	2	4363300	3951477	4363635
$2s^2 2p3d$	$3F^\circ$	3	4379400	3963833	4378814
$2s^2 2p3d$	$3F^\circ$	4	-	3988654	4401309
$2s^2 2p3d$	$1D^\circ$	2	-	3966033	4385007
$2s^2 2p3d$	$3D^\circ$	1	4399500	3975409	4402470
$2s^2 2p3d$	$3D^\circ$	2	4411500	3991878	4413002
$2s^2 2p3d$	$3D^\circ$	3	4426400	4000316	4425526
$2s^2 2p3d$	$3P^\circ$	2	4435400	4006954	4433389
$2s^2 2p3d$	$3P^\circ$	1	4434500	4008947	4435381
$2s^2 2p3d$	$3P^\circ$	0	-	4010358	4436968
$2s^2 2p3d$	$1F^\circ$	3	4475000	4032514	4474373
$2s^2 2p3d$	$1P^\circ$	1	4473400	4032524	4475119

9.6% **0.03%**

2. Oscillator strengths and transition probabilities of the different transitions for Ca XV:

"Weighted oscillator strengths and transition probabilities for the transition ($2s^2 2p^2 \ ^3P - 2s \ 2p^3 \ ^3S^o$) of Ca XV ion."

$\log gf$ (CW), $\log gf$ (EK) and gA (CW) and gA (EK) are the weighted oscillator strengths and transition probabilities calculated by us and by Ekman et al. using the Cowan code and the MCDHF method respectively. g_i and g_k are respectively the statistical weights of the term $^3P - ^3S^o$.

2.Oscillator strengths and transition probabilities of the different transitions for Ca XV:

"Weighted oscillator strengths and transition probabilities for the transition ($2s^2 2p^2 \ ^3P - 2s 2p^3 \ ^3S^o$) of Ca XV ion."

$\log gf$ (CW), $\log gf$ (EK) and gA (CW) and gA (EK) are the wighted oscillator strengths and transition probabilities calculated by us and by Ekman et al. using the Cowan code and the MCDHF method respectively. g_i and g_k are respectively the statistical wights of the term $^3P - ^3S^o$.

λ (nm)	g_i	g_k	$\log gf$		gA	
			(CW)	(EK)	(CW)	(EK)
13.9	5	3	-0.317	-0.462	1.68E+11	1.11E+11
13.5	3	3	-0.599	-0.762	9.22E+10	5.82E+10
13.2	1	3	-1.076	-1.249	3.21E+10	2.00E+10
			22.2%		56.8%	

2.Oscillator strengths and transition probabilities of the different transitions for Ca XV:

"Weighted oscillator strengths and transition probabilities for the transition ($2s^2 2p^2 \ ^3P - 2s 2p^3 \ ^3S^o$) of Ca XV ion."

$\log gf$ (CW), $\log gf$ (EK) and gA (CW) and gA (EK) are the wighted oscillator strengths and transition probabilities calculated by us and by Ekman et al. using the Cowan code and the MCDHF method respectively. g_i and g_k are respectively the statistical wights of the term $^3P - ^3S^o$.

λ (nm)	g_i	g_k	$\log gf$		gA	
			(CW)	(EK)	(CW)	(EK)
13.9	5	3	-0.317	-0.462	1.68E+11	1.11E+11
13.5	3	3	-0.599	-0.762	9.22E+10	5.82E+10
13.2	1	3	-1.076	-1.249	3.21E+10	2.00E+10
			22.2%		56.8%	

"Weighted oscillator strengths and transition probabilities for the transition ($2s^2 2p^2 \ ^3P - 2s 2p^3 \ ^3P^o$) of Ca XV ion."

$\log gf$ (CW), $\log gf$ (EK) and gA (CW) and gA (EK) are the weighted oscillator strengths and transition probabilities calculated by us and by Ekman et al. using the Cowan code and the MCDHF method respectively. g_i and g_k are respectively the statistical weights of the term $^3P-^3P^o$.

λ (nm)	g_i	g_k	$\log gf$		gA	
			(CW)	(EK)	(CW)	(EK)
17.46058	5	3	-1.34	-1.32	1.01E+10	9.54E+09
17.36467	5	5	-0.59	-0.61	5.75E+10	4.91E+10
16.95419	3	1	-1.25	-1.25	1.31E+10	1.20E+10
16.90512	3	3	-1.07	-1.12	1.98E+10	1.61E+10
16.8152	3	5	-1.68	-1.54	4.94E+09	6.15E+09
16.45036	1	3	-1.41	-1.37	9.59E+09	9.66E+09
			3.6%		12.6%	

"Weighted oscillator strengths and transition probabilities for the transition ($2s^2 2p^2 \ ^3P - 2s 2p^3 \ ^3P^o$) of Ca XV ion."

$\log gf$ (CW), $\log gf$ (EK) and gA (CW) and gA (EK) are the wighted oscillator strengths and transition probabilities calculated by us and by Ekman et al. using the Cowan code and the MCDHF method respectively. g_i and g_k are respectively the statistical wights of the term $^3P-^3P^o$.

λ (nm)	g_i	g_k	$\log gf$		gA	
			(CW)	(EK)	(CW)	(EK)
17.46058	5	3	-1.34	-1.32	1.01E+10	9.54E+09
17.36467	5	5	-0.59	-0.61	5.75E+10	4.91E+10
16.95419	3	1	-1.25	-1.25	1.31E+10	1.20E+10
16.90512	3	3	-1.07	-1.12	1.98E+10	1.61E+10
16.8152	3	5	-1.68	-1.54	4.94E+09	6.15E+09
16.45036	1	3	-1.41	-1.37	9.59E+09	9.66E+09

3.6%

12.6%

"Weighted oscillator strengths and transition probabilities for the transition ($2s^22p^2\ ^3P - 2s\ 2p^3\ ^3D^o$) of Ca XV ion."

$\log gf$ (CW), $\log gf$ (EK) and gA (CW) and gA (EK) are the wighted oscillator strengths and transition probabilities calculated by us and by Ekman et al. using the Cowan code and the MCDHF method respectively. g_i and g_k are respectively the statistical wights of the term $^3P-^3D^o$.

λ (nm)	g_i	g_k	$\log gf$		gA	
			(CW)	(EK)	(CW)	(EK)
20.25	5	5	-1.790	-2.105	2.64E+09	1.11E+09
20.22	5	3	-2.992	-3.365	1.66E+08	6.15E+07
20.05	5	7	-0.500	-0.699	5.24E+10	2.88E+10
19.51	3	5	-0.644	-0.815	3.98E+10	2.34E+10
19.48	3	3	-1.399	-1.616	7.02E+09	3.72E+09
18.88	1	3	-0.956	-1.126	2.07E+10	1.24E+10
			17.3%		102.7%	

"Weighted oscillator strengths and transition probabilities for the transition ($2s^2 2p^2 \ ^3P - 2s 2p^3 \ ^3D^o$) of Ca XV ion."

$\log gf$ (CW), $\log gf$ (EK) and gA (CW) and gA (EK) are the wighted oscilltor strengths and transition probabilities calculated by us and by Ekman et al. using the Cowan code and the MCDHF method respectively. g_i and g_k are respectively the statistical wights of the term $^3P-^3D^o$.

λ (nm)	g_i	g_k	$\log gf$		gA	
			(CW)	(EK)	(CW)	(EK)
20.25	5	5	-1.790	-2.105	2.64E+09	1.11E+09
20.22	5	3	-2.992	-3.365	1.66E+08	6.15E+07
20.05	5	7	-0.500	-0.699	5.24E+10	2.88E+10
19.51	3	5	-0.644	-0.815	3.98E+10	2.34E+10
19.48	3	3	-1.399	-1.616	7.02E+09	3.72E+09
18.88	1	3	-0.956	-1.126	2.07E+10	1.24E+10
			17.3%		102.7%	

- When comparing the predicted energy levels with experimental values from NIST and the results from Ekman et al., we find that:

- When comparing the predicted energy levels with experimental values from NIST and the results from Ekman et al., we find that:
 - For configurations $2s^2 2p^2$ and $2s 2p^3$, our results were close to the NIST database by about 4% to 5%. But the configuration $2s^2 2p 3d$ was about 9%.

- When comparing the predicted energy levels with experimental values from NIST and the results from Ekman et al., we find that:
 - For configurations $2s^2 2p^2$ and $2s 2p^3$, our results were close to the NIST database by about 4% to 5%. But the configuration $2s^2 2p 3d$ was about 9%.
 - For configurations $2s^2 2p ns$ ($n=3-5$) and $2s^2 2p np$ ($n=3,4$), there are no values to compare with them in NIST. While, we found values in the Ekman et al. for these configurations except the $2s^2 2p 5s$ configuration.

- When comparing the predicted energy levels with experimental values from NIST and the results from Ekman et al., we find that:
 - For configurations $2s^2 2p^2$ and $2s 2p^3$, our results were close to the NIST database by about 4% to 5%. But the configuration $2s^2 2p 3d$ was about 9%.
 - For configurations $2s^2 2p ns$ ($n=3-5$) and $2s^2 2p np$ ($n=3,4$), there are no values to compare with them in NIST. While, we found values in the Ekman et al. for these configurations except the $2s^2 2p 5s$ configuration.

So, we can say that:

"We got new values with the CW code for the $(2s^2 2p 5s)$ configuration and for the term $(2s^2 2p 4p \ ^1S)$ that did not exist before in any experimental data"

- When comparing the predicted energy levels with experimental values from NIST and the results from Ekman et al., we find that:
 - For configurations $2s^2 2p^2$ and $2s 2p^3$, our results were close to the NIST database by about 4% to 5%. But the configuration $2s^2 2p 3d$ was about 9%.
 - For configurations $2s^2 2p ns$ ($n=3-5$) and $2s^2 2p np$ ($n=3,4$), there are no values to compare with them in NIST. While, we found values in the Ekman et al. for these configurations except the $2s^2 2p 5s$ configuration.

So, we can say that:

"We got new values with the CW code for the $(2s^2 2p 5s)$ configuration and for the term $(2s^2 2p 4p ^1S)$ that did not exist before in any experimental data"

- The results of weighted oscillator strengths $\log gf$ and transition probabilities gA for selected transitions obtained by CW code are only compared with Ekman et al. values because there is no data to compare in NIST, and we find that:

- The results of weighted oscillator strengths $\log gf$ and transition probabilities gA for selected transitions obtained by CW code are only compared with Ekman et al. values because there is no data to compare in NIST, and we find that:
 - Our results of the weighted oscillator strengths and transition probabilities for $2s^2 2p^2 \ ^3P - 2s \ 2p^3 \ ^3P^o$ transitions were in good agreement (3.6% for $\log gf$ and 12% for gA) with the values of Ekman et al.

- The results of weighted oscillator strengths $\log gf$ and transition probabilities gA for selected transitions obtained by CW code are only compared with Ekman et al. values because there is no data to compare in NIST, and we find that:
 - Our results of the weighted oscillator strengths and transition probabilities for $2s^2 2p^2 \ ^3P - 2s \ 2p^3 \ ^3P^o$ transitions were in good agreement (3.6% for $\log gf$ and 12% for gA) with the values of Ekman et al.
 - And for the other transitions, the results of weighted oscillator strengths were close to Ekman et al. values by about 20% for $2s^2 2p^2 \ ^3P - 2s \ 2p^3 \ ^3S^o$ and 17% for $2s^2 2p^2 \ ^3P - 2s \ 2p^3 \ ^3D^o$. While, the results of transition probabilities for $2s^2 \ 2p^2 \ ^3P - 2s \ 2p^3 \ ^3D^o$ was about 100% to the values of the Ekman et al., and for $2s^2 \ 2p^2 \ ^3P - 2s \ 2p^3 \ ^3S^o$ transition is less than 60% the Ekman et al. values.

- The results of weighted oscillator strengths $\log gf$ and transition probabilities gA for selected transitions obtained by CW code are only compared with Ekman et al. values because there is no data to compare in NIST, and we find that:
 - Our results of the weighted oscillator strengths and transition probabilities for $2s^2 2p^2 \ ^3P - 2s \ 2p^3 \ ^3P^o$ transitions were in good agreement (3.6% for $\log gf$ and 12% for gA) with the values of Ekman et al.
 - And for the other transitions, the results of weighted oscillator strengths were close to Ekman et al. values by about 20% for $2s^2 2p^2 \ ^3P - 2s \ 2p^3 \ ^3S^o$ and 17% for $2s^2 2p^2 \ ^3P - 2s \ 2p^3 \ ^3D^o$. While, the results of transition probabilities for $2s^2 \ 2p^2 \ ^3P - 2s \ 2p^3 \ ^3D^o$ was about 100% to the values of the Ekman et al., and for $2s^2 \ 2p^2 \ ^3P - 2s \ 2p^3 \ ^3S^o$ transition is less than 60% the Ekman et al. values.

Indeed,

this study extremely important to overcome this great lack on atomic structure data for Ca XV ion and it provides the missing values of NIST database and supports the results given by Ekman et al., specially for the weighted oscillator strengths and transition probabilities.

Indeed,

this study extremely important to overcome this great lack on atomic structure data for Ca XV ion and it provides the missing values of NIST database and supports the results given by Ekman et al., specially for the weighted oscillator strengths and transition probabilities.

Thank you for your attention

Thank you for your attention

شكرا لحسن استماعكم

Thank you for your attention

شكرا لحسن استماعكم

Hvala na pažnji

Thank you for your attention

شكرا لحسن استماعكم

Hvala na pažnji